

There may be a program in the Startup Menu called Wrapperlite that causes a "ChoiceSeat" screen on startup. To remove the "ChoiceSeat" screen on startup: (Note: the touchscreen will not operate during this procedure, however the operation can be done entirely from a keyboard.)

Start the computer while pressing and holding down the "Shift" key. This will skip the startup menu and start the computer in "Safe" mode. Select the Start button on the bottom left corner of the screen and then select Setting/ Taskbar & Startmenu (the TAB key will cycle through available selections on the desktop and the arrow keys will scroll menus). Select the tab "Startmenu Programs". Select Remove and highlight startup/wrapperlite. Select Remove. Wrapperlite should no longer appear under startup. Restart the computer.

Please note that a mouse cannot be use at the same time as the touchscreen. The touchscreen acts as a serial mouse. The use of an additional mouse while the touchscreen is active will result in an "FF input" warning during boot-up and will freeze the system.

The view angle of the monitor may be limited due to the use of an Image Directing Film located beneath the touchscreen plate. To remove the film: Remove the screen cover by unscrewing the 4 screws located on the front sides of the screen cover. Lift the screen cover and touchscreen plate and remove the plastic film. Replace the touchscreen plate and screen cover and secure with the 4 screws.

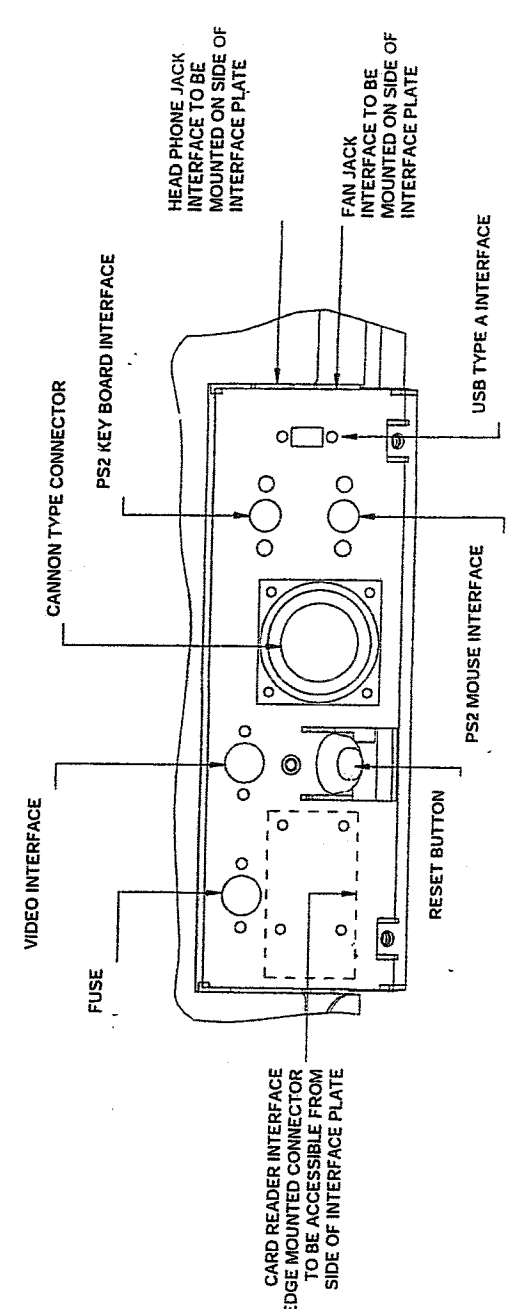
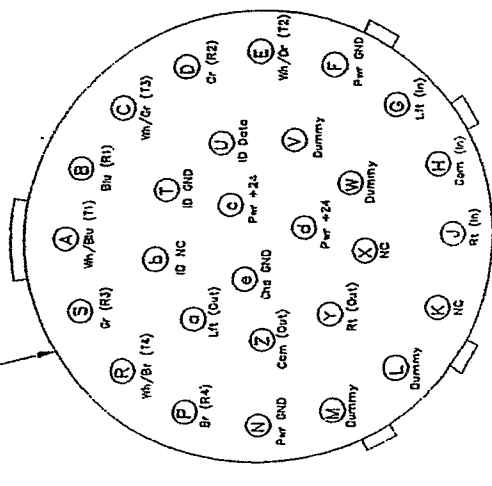
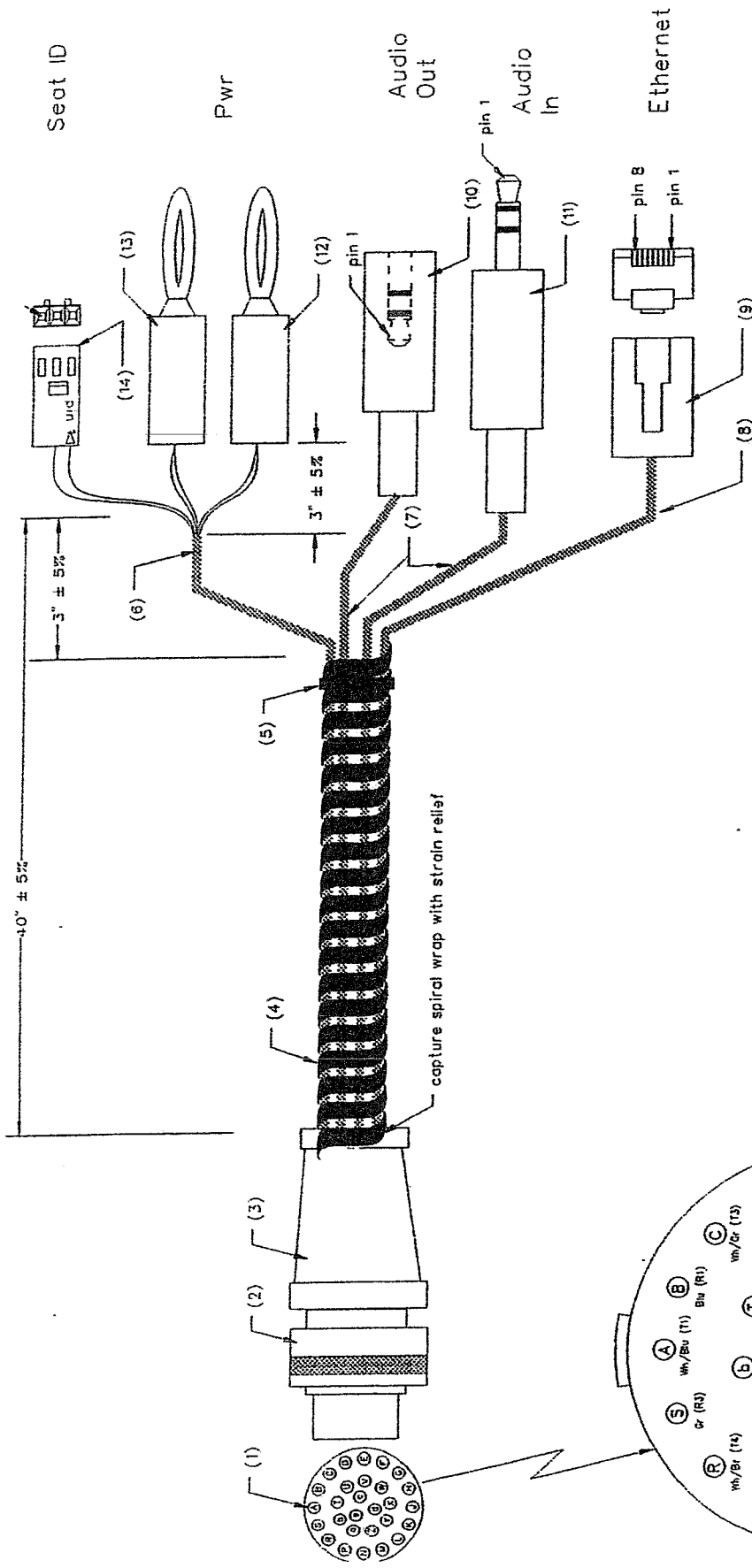

1. Scope

This document specifies the Integrated Multimedia Display Module (IMDM) Version 2. The assigned King part number for this device is 4802692.

The IMDM is an interactive multimedia terminal intended for the delivery of online goods, services and advertising to users in public space.

1.1. Item definition

The IMDM comprises the following sub-assemblies:

Mechanical housing

Screen Assembly

Main computer module w/ Qty (2) PCMCIA Slots

Hard Disk Local storage

TV Card

I/O and Control module

16 Bit Ethernet PCMCIA Card

Interconnect panel

A block diagram is shown in **Figure 1**

2. Applicable Documents

- CAMBO PCMCIA Ether-C16 LAN Card #5053901608 Dated: 8/18/1999
- BILLIONTON PCMCIA DVD/MPEG2 Card #00045816
- TOSHIBA 10.4" TFT-LCD Module #LTM10C306J Spec #G990027-T993 Dated: 07/21/1999
- Micro Touch System 10.4" ToughTouch Flat Sensor#83-556X-01X
- Hitachi 2.5" ATA-4 Hard Disk Model #DK238A-43
- Hitachi Motherboard Model # EP4E
- 3M Image Directing Film (IDF) II 20 degrees P/N 98-0440-0036-6
- Cannon Circular Connector #192922-1290
- Power Management Specifications ACPI V1.0 and APM V1.2
- UL 1950
- FCC Part 15 Class A

RESTRICTION ON USE, DUPLICATION, OR DISCLOSURE OF PROPRIETARY INFORMATION

This document contains information proprietary to King Products Inc. Any disclosure, use, or duplication of this document or any of the information contained herein for other than the specific purpose for which it was disclosed by King Products Inc. is expressly prohibited, except as King Products Inc. may otherwise agree in writing.

3. Requirements

3.1. System Design

The following paragraphs define the system design characteristics of the IMDM

3.1.1. Electrical Interfaces

The electrical interfaces shall use one or more external interface connectors which shall be hard-mounted to the IMDM casing.

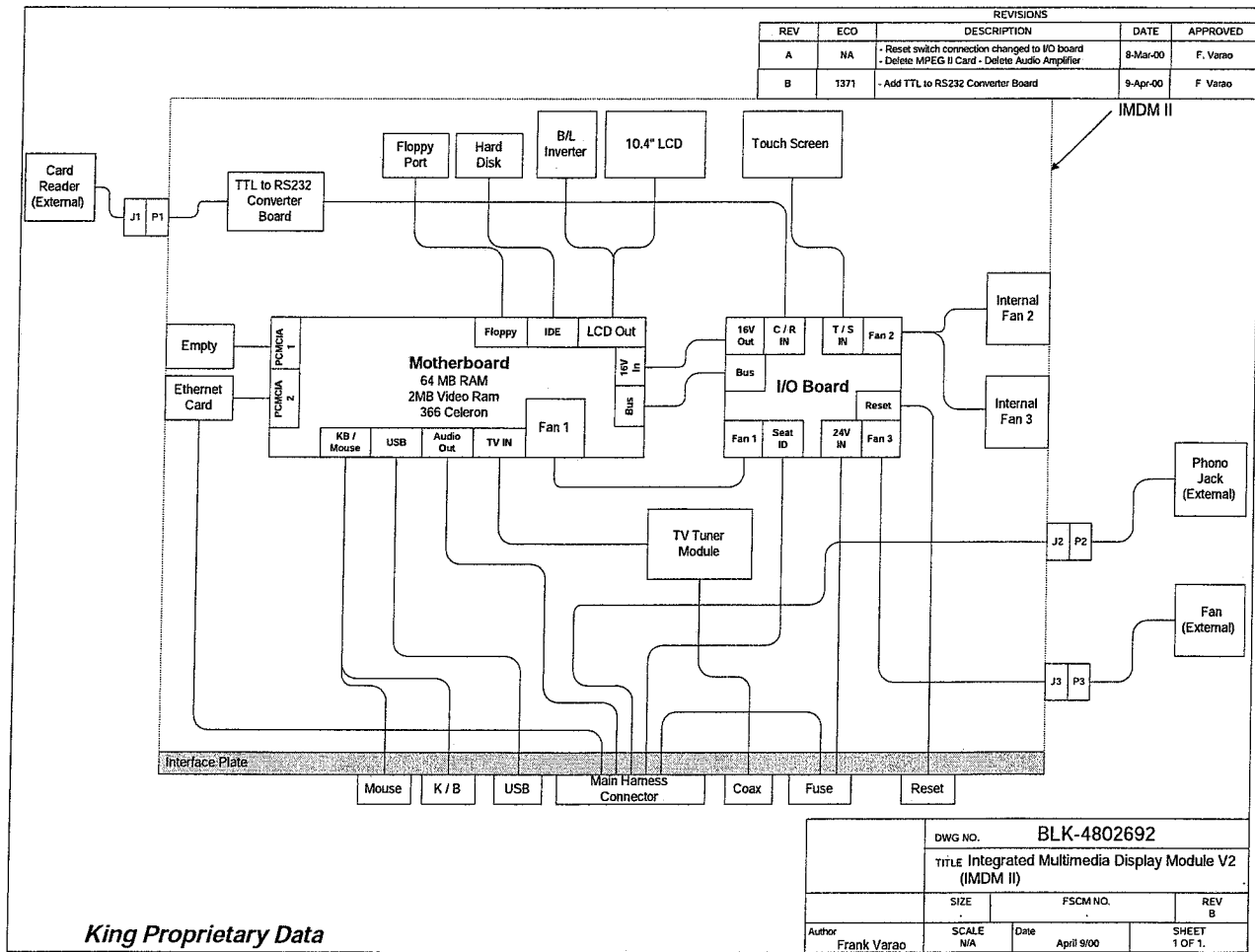

Figure 1

RESTRICTION ON USE, DUPLICATION, OR DISCLOSURE OF PROPRIETARY INFORMATION

This document contains information proprietary to King Products Inc. Any disclosure, use, or duplication of this document or any of the information contained herein for other than the specific purpose for which it was disclosed by King Products Inc. is expressly prohibited, except as King Products Inc. may otherwise agree in writing.

3.1.1.1. Input Power

3.1.1.1.1. Input Voltage

The IMDM shall operate as defined herein when supplied with 24V DC, +5%/ -10%

3.1.1.1.2. Noise and Ripple

The IMDM shall operate as defined herein with up to 50mV input voltage noise and up to 200mV input voltage ripple.

3.1.1.1.3. Input Current

Maximum load current for the IMDM is 1.5 Amps (RMS) when supplied with voltage in accordance with para. 3.1.1.1.1

3.1.1.1.4. Inrush Current

Maximum inrush current during turn ON shall not exceed 25% of the rated maximum load current as specified in para 3.1.1.1.3

3.1.1.1.5. Fuse

A fuse of sufficient rating shall be incorporated into the IMDM to protect the IMDM from electrical damage. The fuse shall be located on the interface panel and be replaceable without requiring any disassembly of the IMDM. Ref Figure 3

3.1.1.1.6. Grounding

The IMDM shall have a ground/earth connection located on the interface panel. Ref Figure 3

3.1.1.1.7. Hold up Time

The IMDM shall continue to operate when the voltage input drops 15% below the minimum rated input voltage for up to 16 msec.

3.1.2. Cooling

The IMDM will use forced air for cooling. Qty (1) fan shall be mounted on the motherboard to facilitate CPU heat removal, and Qty (2) Fans will be mounted on the interior IMDM casing. There shall be provisioning for Qty (1) external fan to be connected to the IMDM to assist in directing airflow away from the IMDM.

RESTRICTION ON USE, DUPLICATION, OR DISCLOSURE OF PROPRIETARY INFORMATION

This document contains information proprietary to King Products Inc. Any disclosure, use, or duplication of this document or any of the information contained herein for other than the specific purpose for which it was disclosed by King Products Inc. is expressly prohibited, except as King Products Inc. may otherwise agree in writing.

3.2. Interface Requirements

The IMDM is designed to be used in multimedia and electronic commerce applications. The device is therefore designed to support human interactions. Human interactions include those intended for access by user population, and those intended for service personnel. These interfaces are specified in the following subparagraphs.

3.2.3. LCD Display Screen

The IMDM shall contain a flat panel LCD display. The nominal active viewing area shall be 10.4 inches diagonal. The aspect ratio shall be 4:3, and the panel shall be mounted in landscape orientation. The resolution of the display panel shall be 1024 by 768 pixels, i.e. XGA. Additional specifications as per TOSHIBA spec. #G990027-T993 Dated 07/21/1999, with the exception of luminance. Max. luminance shall be 200 Nits +15% / -10% when measured in accordance to para 11.1 of the TOSHIBA spec.

3.2.4. Touch Screen

The IMDM shall contain a touch screen, mounted directly over and registered to the LCD panel. The touch screen technology shall be capacitive. The specified resolution of the touch screen shall be 1024 by 1024. The touch screen shall be specified to meet UL 1950 para. 4.2.4 Steel Ball Test. Additional specifications as per MicroTouch ToughTouch Sensor spec. #83-556X-01X. The touch screen shall appear as a mouse device to the main processor.

3.2.5. Viewing cone

The selected display panel shall be specified as having a contrast ratio of ≥ 10 , within a viewing cone of +30/-30 degrees horizontal and +10/-20 degrees vertical. When installed in the IMDM, with the specified Image Directing Film (IDF) material secured over the LCD, the viewing cone shall be altered by 20 Degrees, as shown in **Figure 2**. Specifications of the IDF as per 3M IDF II 20 Degrees #98-0440-0036-6.

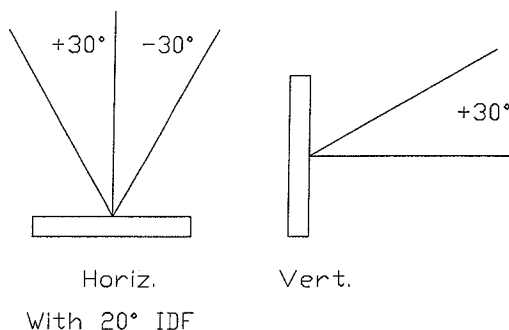

Figure 2

RESTRICTION ON USE, DUPLICATION, OR DISCLOSURE OF PROPRIETARY INFORMATION

This document contains information proprietary to King Products Inc. Any disclosure, use, or duplication of this document or any of the information contained herein for other than the specific purpose for which it was disclosed by King Products Inc. is expressly prohibited, except as King Products Inc. may otherwise agree in writing.

3.2.6. Analog Video In

The IMDM shall accept North American broadcast TV video standard (NTSC) over an RF coaxial cable, with a nominal input impedance of 75ohms - unbalanced.

3.2.7. Ethernet

The IMDM shall provide an interface to an Ethernet based network. The interface shall be via a PCMCIA 16Bit Ethernet Card providing 10/100Mbps data rates. Additional specifications as per CAMBO spec. #5053901608 Dated 8/17/1999.

3.2.8. Seat ID

The IMDM shall contain a 3 wire interface to enable a unique location code to be assigned to each IMDM for identification purposes.

3.2.9. Reset Switch

The IMDM shall have a reset switch that can be used to reset the motherboard hardware. The switch shall be located on the interface panel. Ref Figure 3

3.2.10. USB

The IMDM shall provide an interface for standard USB type "A" device connection. Ref Figure 3

3.2.11. Keyboard and Mouse

The IMDM shall provide an interface for standard PS/2 mouse and keyboard devices Ref Figure 3
It is understood that the PS/2 mouse will not operate as long as the PS/2 touch screen is active / connected.

3.2.12. Headphone Audio

The IMDM shall provide a standard 3.5mm stereo headphone jack output at the interface plate. Interface to the headphone shall be provided by use of a plug-in connector. The audio level at the headphone jack shall be as specified in para 3.4.1.4. Ref Figure 1 & Figure 3

3.2.13. Floppy Disk

Floppy drive access, when required, shall be supported via either USB on the interface plate, or internal connection. Access to the internal connector shall be clearly facilitated once the rear cover of the IMDM has been removed. No other disassembly will be required to mate the floppy connection.

3.2.14. CD-ROM

CD-ROM drive access, when required, shall be supported via either USB on the interface plate, or PCMCIA interface card. Access / removal of the PCMCIA card shall not require any internal mechanical disassembly of the IMDM. Removal of an external cover plate for card access shall be acceptable.

RESTRICTION ON USE, DUPLICATION, OR DISCLOSURE OF PROPRIETARY INFORMATION

This document contains information proprietary to King Products Inc. Any disclosure, use, or duplication of this document or any of the information contained herein for other than the specific purpose for which it was disclosed by King Products Inc. is expressly prohibited, except as King Products Inc. may otherwise agree in writing.

3.2.15. Card Reader

The IMDM shall be capable of interfacing to a MAGTEK card reader P/N #99875146 (Tracks 1&2). Interface to the Card Reader shall be provided by use of a plug-in connector located at the interface plate. Specifications of the Card Reader as per MAGTEK card reader P/N #99875146. Ref Figure 1 & Figure 3

3.2.16. External Fan

The IMDM shall be capable of interfacing to an External Fan. Interface to the External Fan shall be provided by use of a plug-in connector located at the interface plate. Ref Figure 1 & Figure 3

3.2.17. Main Harness Connector

The IMDM shall provide, with the exception of the Analog Video In (coax), a single barrel type connector. The connector shall have provisioning for no less than 28 pins, and shall be keyed, with a locking mechanism. Ref Figure 1 & Figure 3

3.3. Connector Locations

Connectors shall be located on the Interface Plate as per Figure 3

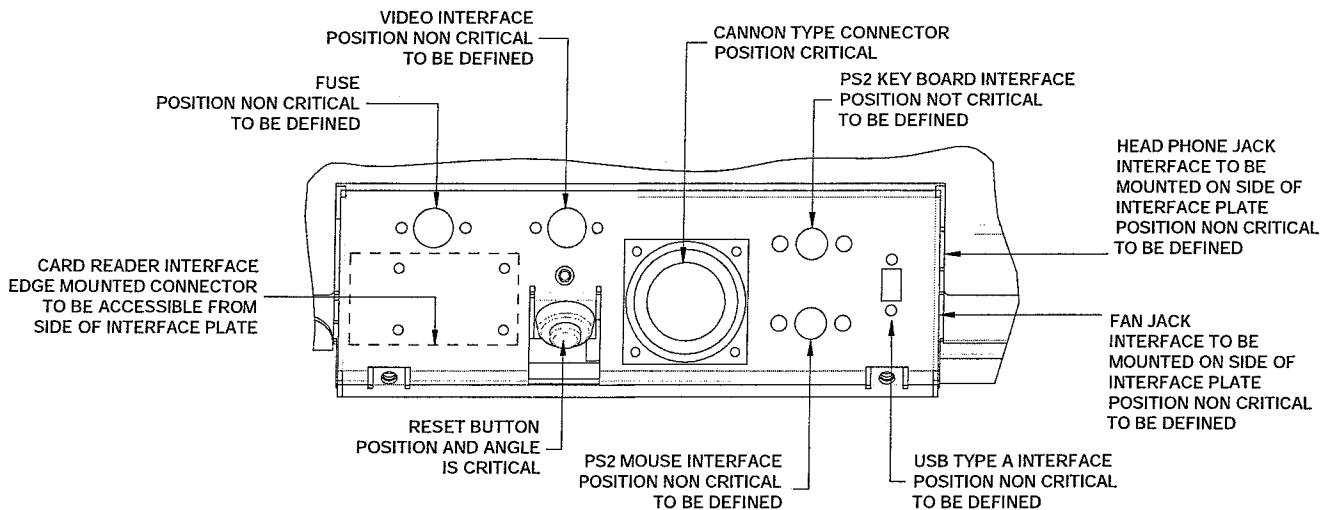

Figure 3

RESTRICTION ON USE, DUPLICATION, OR DISCLOSURE OF PROPRIETARY INFORMATION

This document contains information proprietary to King Products Inc. Any disclosure, use, or duplication of this document or any of the information contained herein for other than the specific purpose for which it was disclosed by King Products Inc. is expressly prohibited, except as King Products Inc. may otherwise agree in writing.

3.4. System Characteristics

The following paragraphs define the characteristics of the IMDM

3.4.1. Function & Performance

The IMDM shall contain the following features and functions

3.4.1.1. Processor

The IMDM shall use a processor chip manufactured by Intel. The CPU shall be Celeron 366 MHz or better.

3.4.1.2. Chipset

The chipset shall be Intel DX or equivalent, or better.

3.4.1.3. Graphics Chipset

The graphics chipset shall be C&T 69000 with 2MB of video RAM or equivalent, or better.

3.4.1.4. Audio Out

The IMDM motherboard shall provide Stereo audio out. The output level shall be 80dBA @ 1kHz Max.

3.4.1.5. MPEG Decoding

The IMDM shall provision for MPEG 2 hardware decoding. Hardware implementation shall be by use of a PCMCIA card. Access / removal of the card shall not require any internal mechanical disassembly of the IMDM. Removal of an external cover plate for card access shall be acceptable. Additional specifications of the MPEG 2 card as per BILLIONTON PCMCIA DVD/MPEG2 Card #00045816

3.4.1.6. TV Capture/Tuner

The IMDM shall be able to process and display TV video, and select incoming TV channel. The device chipset shall be the Brooktree BT879 or equivalent, or better.

3.4.1.7. Network

The IMDM shall provide 10/100 baseT switched Ethernet functionality. Hardware implementation shall be by use of a PCMCIA card. Access / removal of the card shall not require any internal mechanical disassembly of the IMDM. Removal of an external cover plate for card access shall be acceptable. Additional specifications as per CAMBO spec. #5053901608 Dated 8/17/1999.

3.4.1.8. Storage and Memory

The IMDM shall have 64MB of RAM and a 2.5" laptop type hard drive with the capacity of at least 4GB. Additional specifications of the Hard Drive as per Hitachi Model DK238A-43 or equivalent, or better.

The addition of 128 MB of RAM shall be a specific supported option.

RESTRICTION ON USE, DUPLICATION, OR DISCLOSURE OF PROPRIETARY INFORMATION

This document contains information proprietary to King Products Inc. Any disclosure, use, or duplication of this document or any of the information contained herein for other than the specific purpose for which it was disclosed by King Products Inc. is expressly prohibited, except as King Products Inc. may otherwise agree in writing.

3.4.1.9. Software

3.4.1.9.1. Operating System

The IMDM shall be compatible with Windows 98SE, and Windows 2000. The IMDM as specified in this document does not include the operating system.

3.4.1.9.2. Drivers

The IMDM shall be supplied complete with drivers that are not released by the operating system manufacturer as listed in the Operating System section of this document.

3.4.1.10. Video

The IMDM shall be capable of receiving over the relevant input interface and displaying on the display screen any combination of the following 3 types of video; analog video, digital video and graphic video.

The analog video shall be supplied to the IMDM via external Coax connection.

The digital video shall be MPEG1 or MPEG2 format.

Graphic video shall be generated

3.4.1.11. Graphic Video

The graphics video device that renders data shall operate at a native 1024 X 768 resolution.

3.4.1.12. Micro-Controller

The IMDM shall include hardware resources to perform the following functions:

- Watchdog
- Temperature monitoring
- Seat ID number

3.4.1.13. Power Management

The IMDM shall comply with ACPI V1.0 and APM V1.2

RESTRICTION ON USE, DUPLICATION, OR DISCLOSURE OF PROPRIETARY INFORMATION

This document contains information proprietary to King Products Inc. Any disclosure, use, or duplication of this document or any of the information contained herein for other than the specific purpose for which it was disclosed by King Products Inc. is expressly prohibited, except as King Products Inc. may otherwise agree in writing.

3.5. Physical Characteristics.

The IMDM shall exhibit the physical dimensions shown in Figure 4.

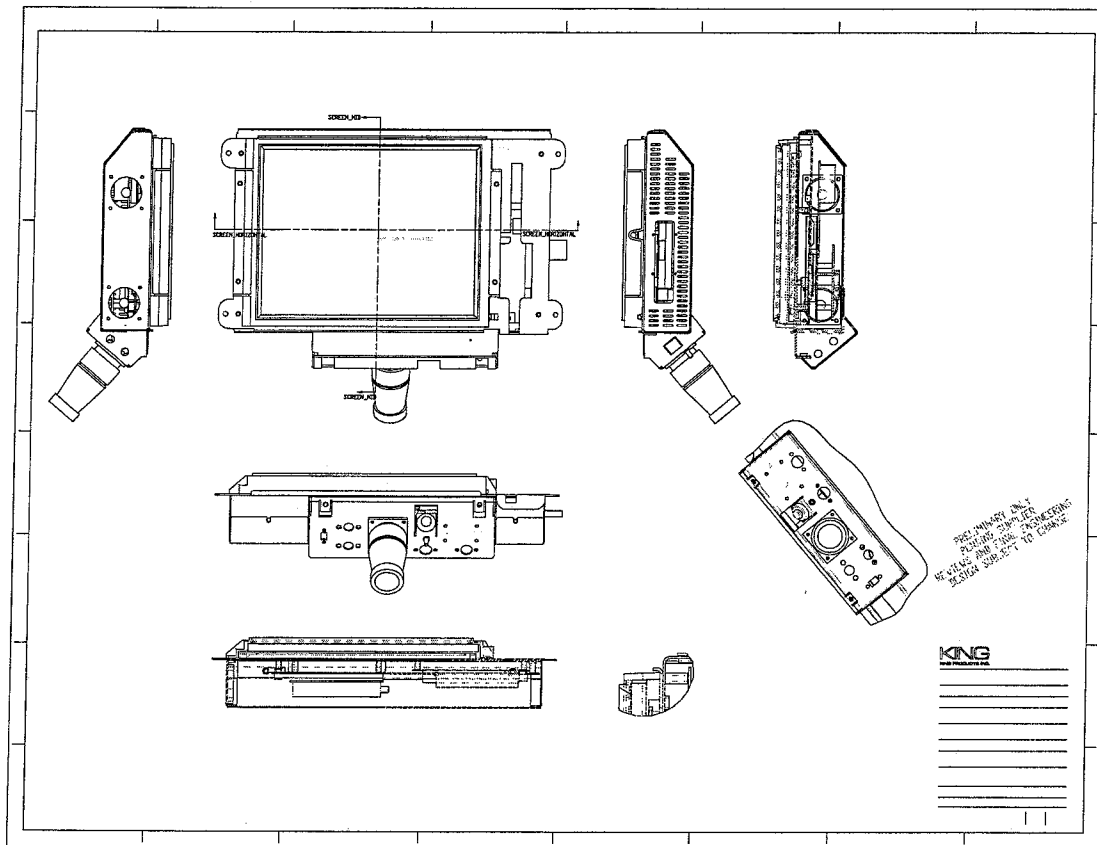

Figure 4

3.5.1. Exterior Finish

The IMDM shall have a zinc coat exterior finish, incorporating a black ABS/PC blend plastic bezel. The chassis shall be corrosion resistant. It is understood that the IMDM will be installed indoors, where the environmental conditions are in accordance with para 3.8

3.6. Reliability

The IMDM shall have a predicted mean time between failure (MTBF) of not less than 40,000 hours. It is understood that the IMDM will be installed indoors, where the environmental conditions are in accordance with para 3.8

RESTRICTION ON USE, DUPLICATION, OR DISCLOSURE OF PROPRIETARY INFORMATION

This document contains information proprietary to King Products Inc. Any disclosure, use, or duplication of this document or any of the information contained herein for other than the specific purpose for which it was disclosed by King Products Inc. is expressly prohibited, except as King Products Inc. may otherwise agree in writing.

3.7. Maintainability

The IMDM shall be designed for easy maintenance. No special tooling shall be required to disassemble the IMDM. Cable connector disconnects shall support the maintenance philosophy.

3.8. Environmental Conditions.

The IMDM shall be compliant to the functional requirements of this specification when mounted in free ambient air at the 'Min' and 'Max' values as below.

	Min	Max	Notes
Operating temperature	0C	+35C	Temp of air at IMDM air inlet
Operating humidity	5%	95%	Non condensing
Storage temperature	-20C	+60C	

3.9. Acoustic Noise Generation

The IMDM with the rated input voltage and loading shall not generate more than 65 dbA at maximum ambient temperature.

3.10. Design and Construction

3.10.1. Materials, Processes and Parts

The IMDM shall use standard and readily available parts and subassemblies, to a practical maximum extent. Full custom, or use of non-readily available components shall be kept to a practical minimum.

3.11. Certification

3.11.1. EMC/EMI

The IMDM shall meet FCC Part 15 Class A

3.11.2. Safety

The IMDM shall meet UL 1950

The IMDM shall be Safety Extra Low Voltage (SELV) compliant for Class III rating.

RESTRICTION ON USE, DUPLICATION, OR DISCLOSURE OF PROPRIETARY INFORMATION

This document contains information proprietary to King Products Inc. Any disclosure, use, or duplication of this document or any of the information contained herein for other than the specific purpose for which it was disclosed by King Products Inc. is expressly prohibited, except as King Products Inc. may otherwise agree in writing.